

XM
426-3/1

1

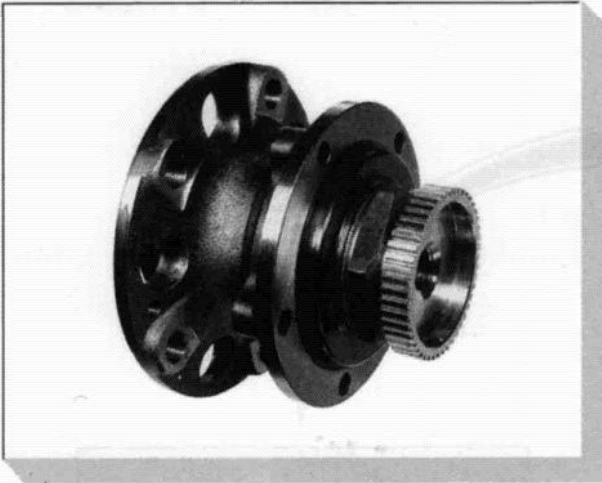

88-604

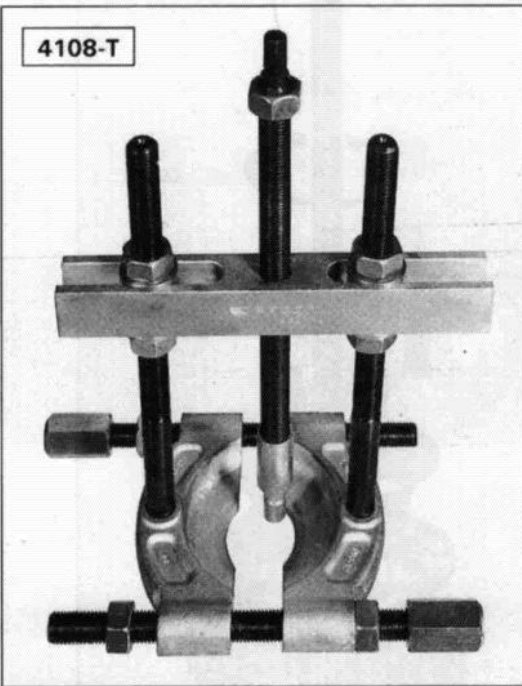
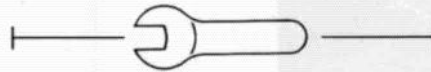

4108-T

88-120

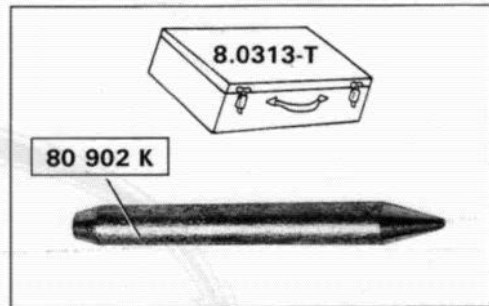

80 902 K

78-360

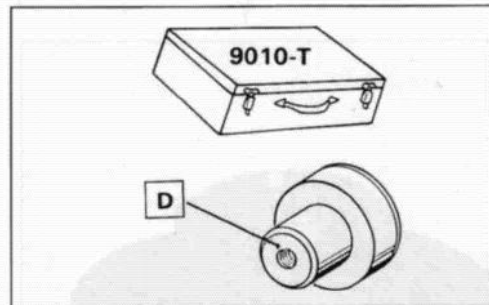

9010-T

D

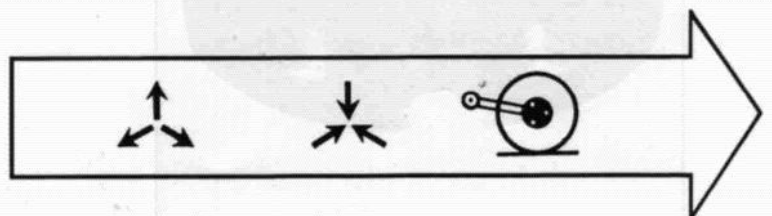

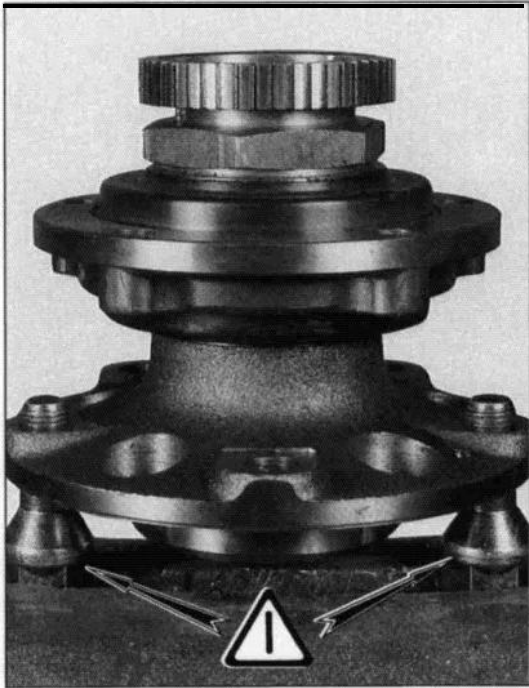

88-674

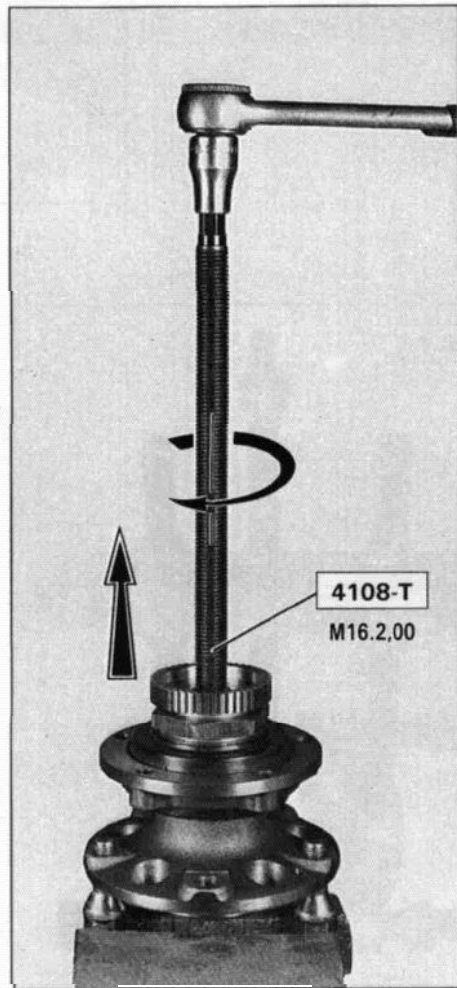
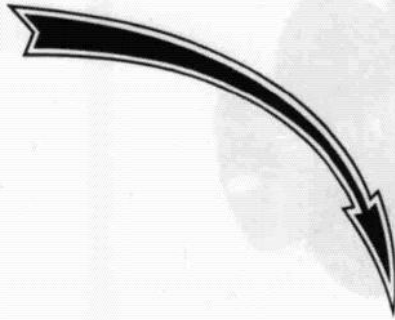

88-678

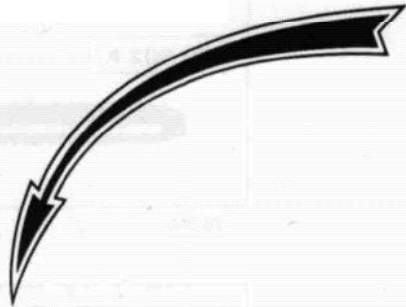

88-679



8

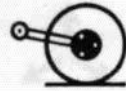

XM
426-3/1

3

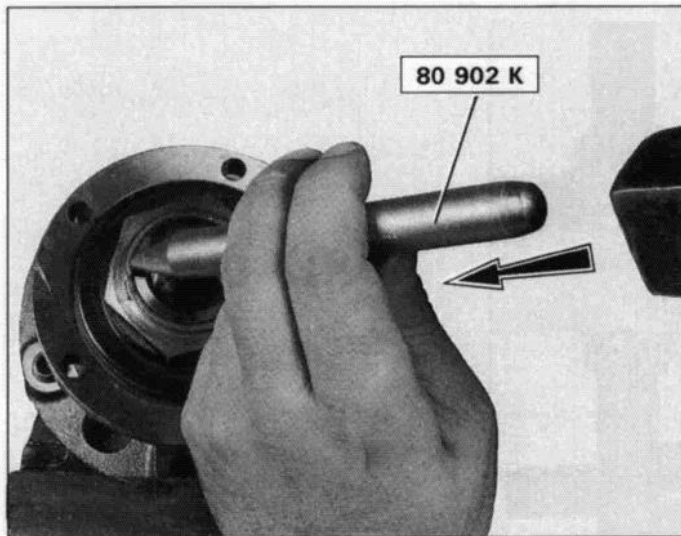

88-677

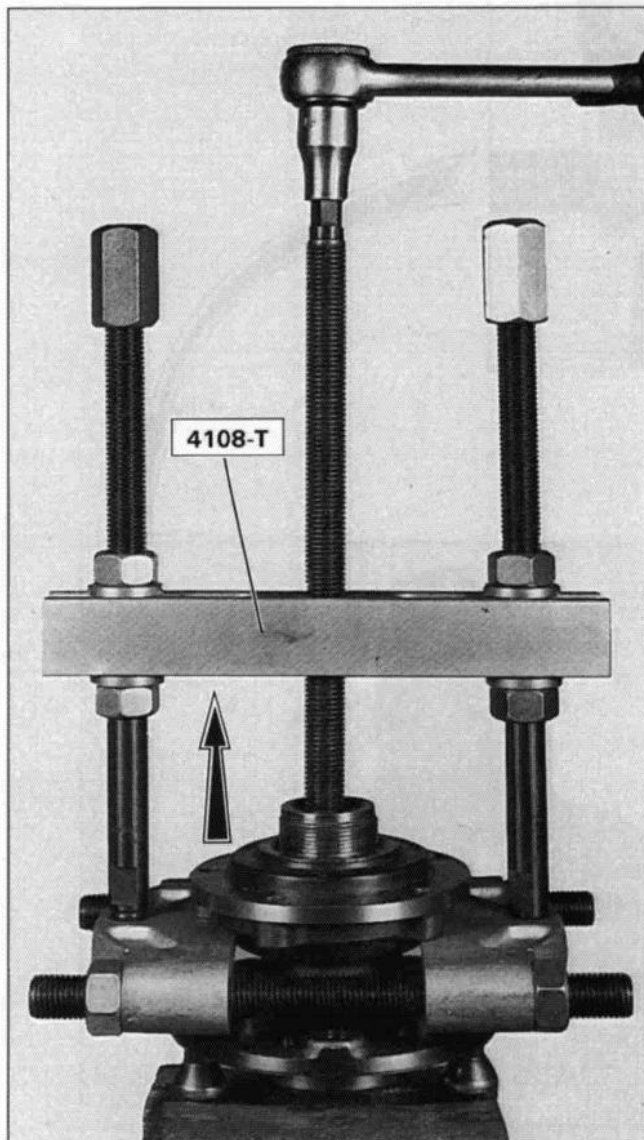

88-671

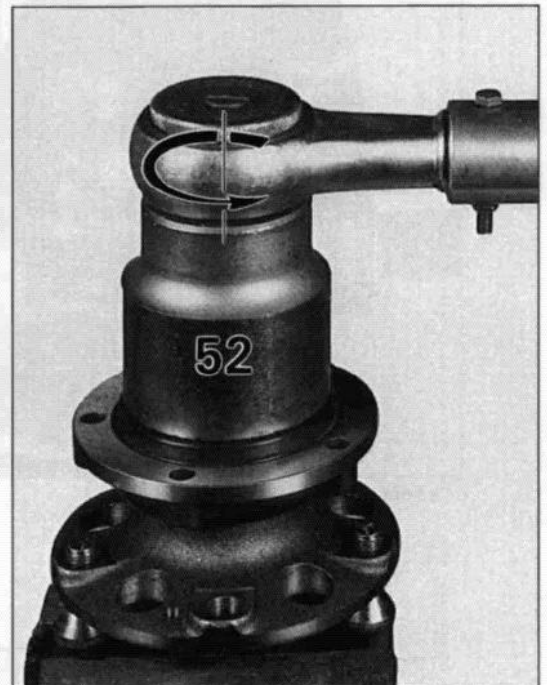

88-670

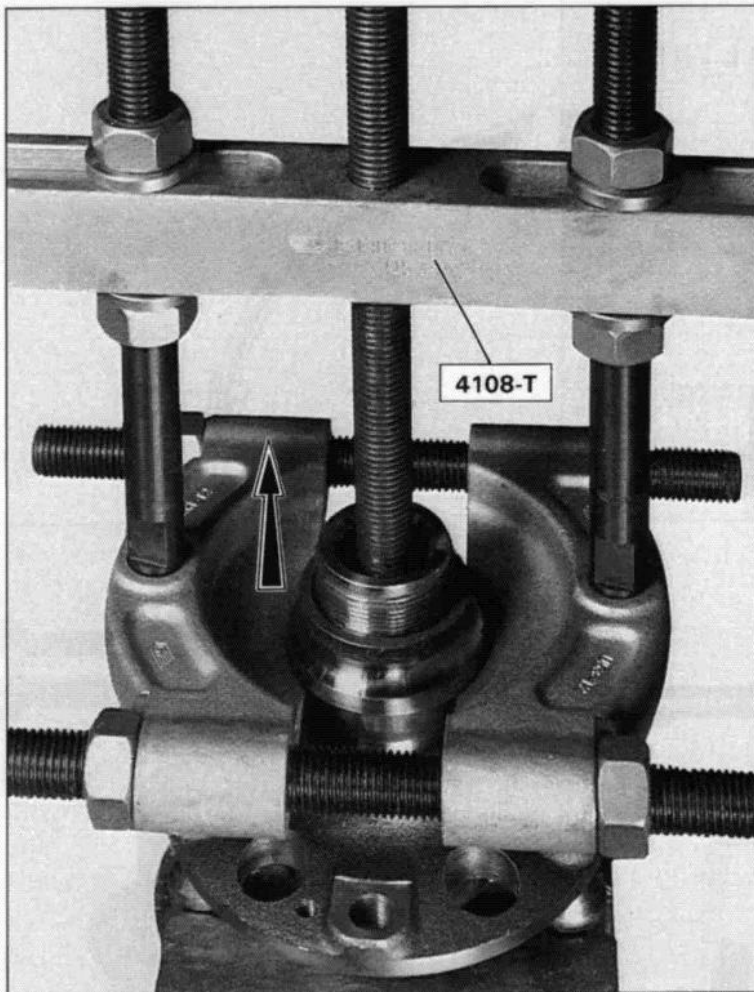
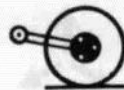

88-665

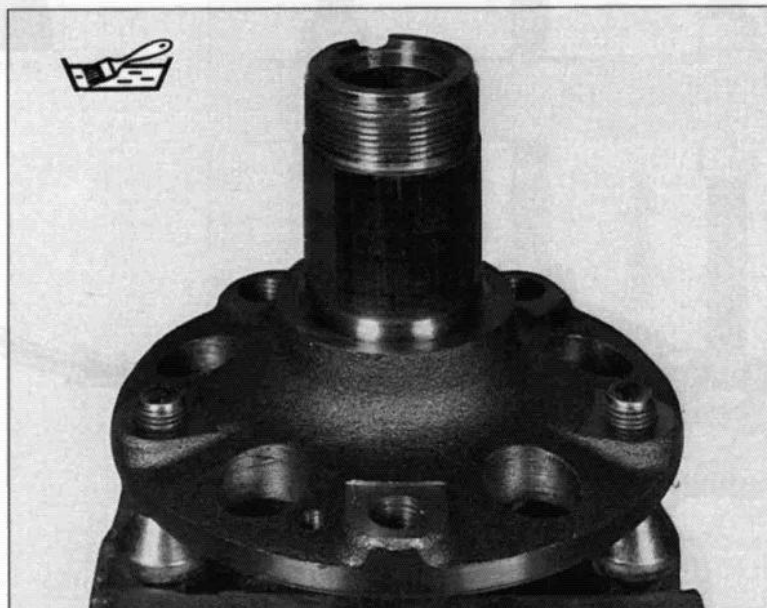

88-664



08

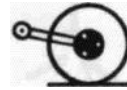

426-3/1 XM

5

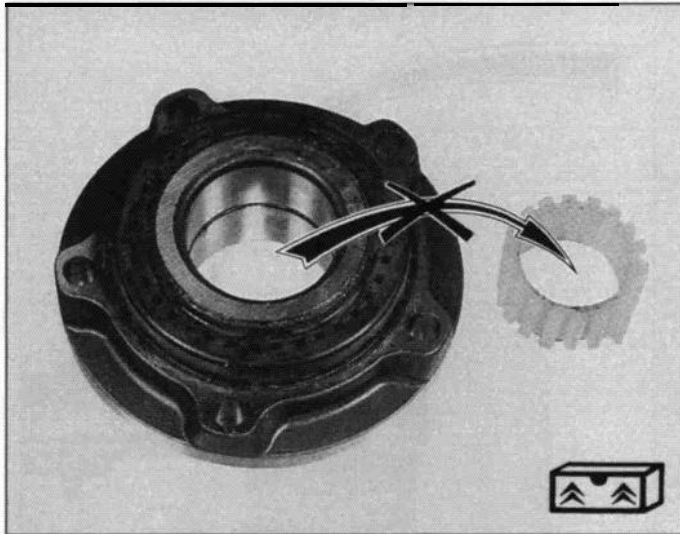

88-733



88 682

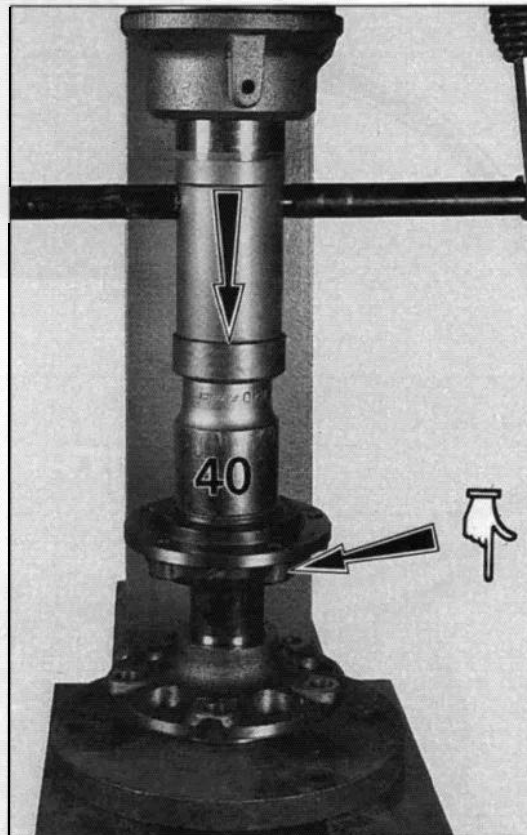

88-668

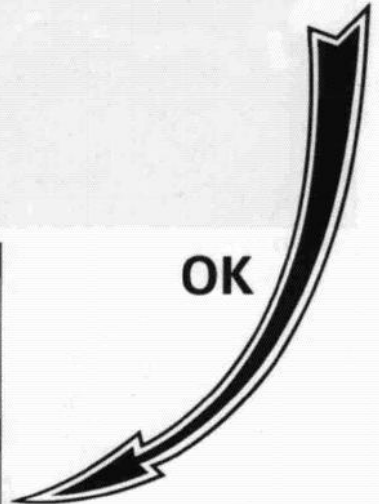

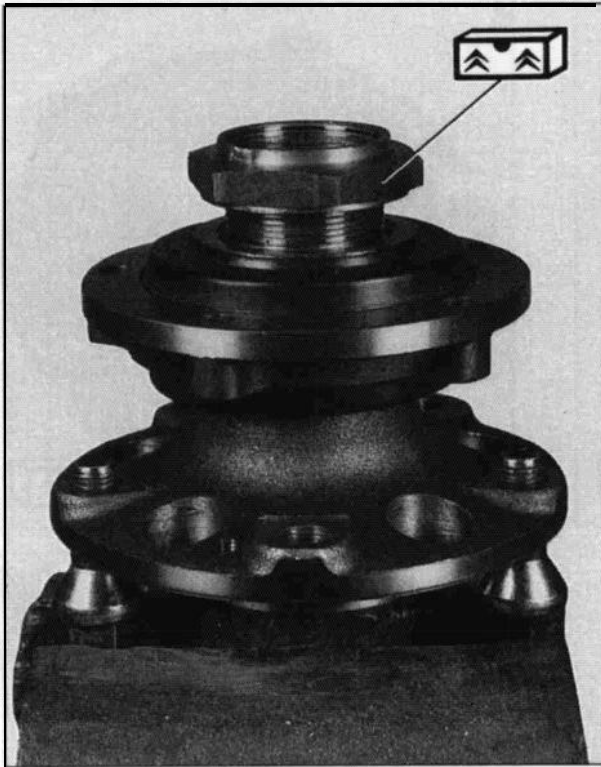
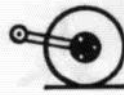

88-672

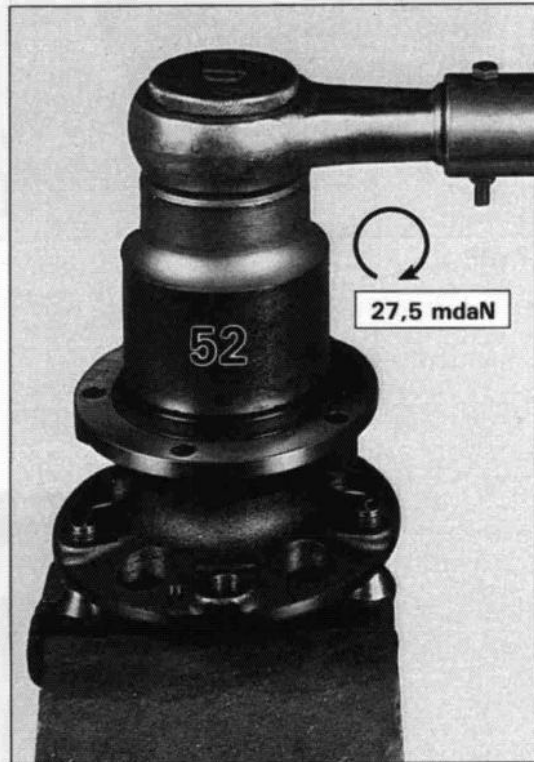
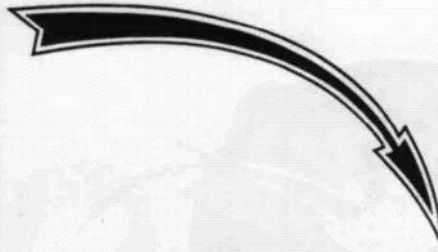

88-670

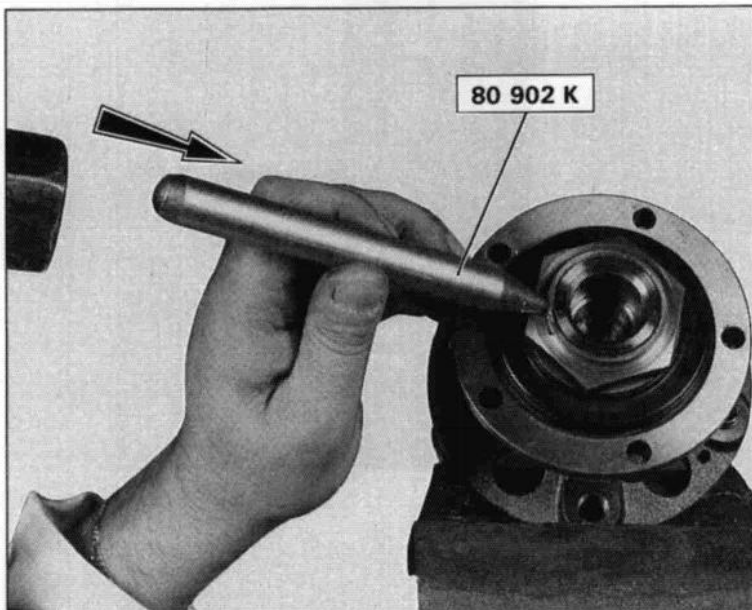
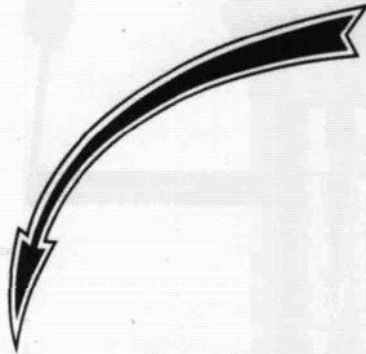

88-680



8

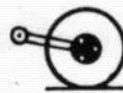

XM
426-3/1

7

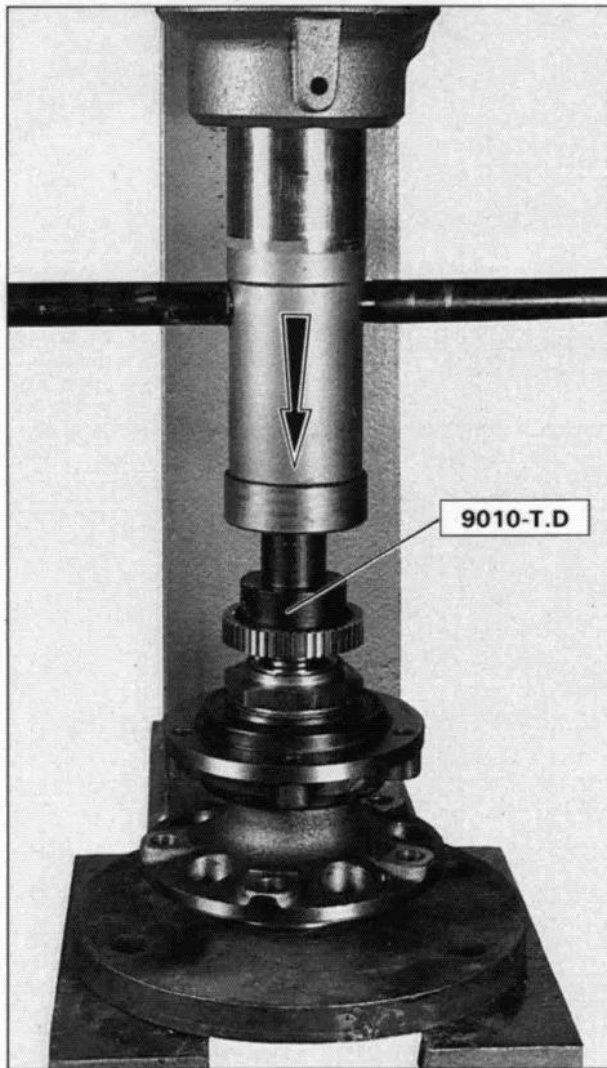

88-667

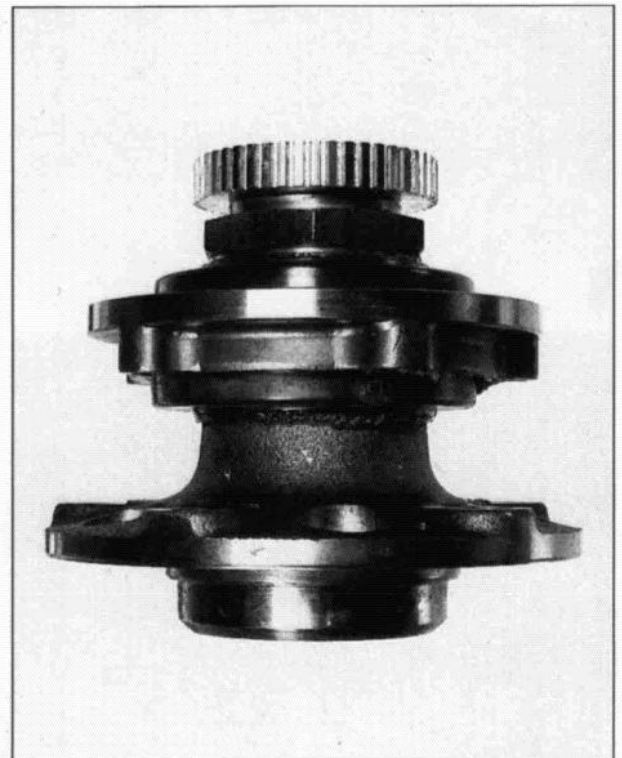
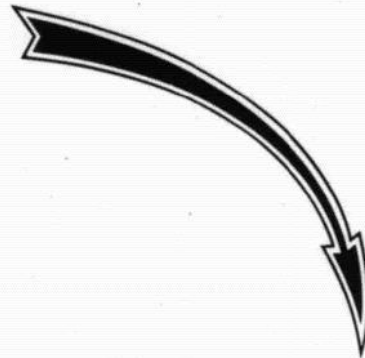

88-603